

Republic of the Philippines
Province of Iloilo
MUNICIPALITY OF OTON
OFFICE OF THE SANGGUNIANG BAYAN

EXCERPTS from the Minutes of the Sangguniang Bayan of Oton, Iloilo in its Regular Session held at the Municipal Session Hall last February 21, 2001 at 2:00 in the afternoon.

PRESENT:	Hon. Jose V. Olivares, Jr.	Vice Mayor (Presiding Officer)
	Hon. Jose Neil P. Olivares	SB Member
	Hon. Francisca C. Espeleta	SB Member (Asst. Floor Leader)
	Hon. Vicente B. Flores, Jr.	SB Member (Floor Leader)
	Hon. Perfecto C. Sabio	SB Member
	Hon. Felimon Gregorio M. Calvo	SB Member
	Hon. Honorato P. Nad	SB Member
	Hon. Jose F. Tinapon III	SB Member
	Hon. Mario D. Balandra	SB Member
	Hon. Edgar N. Javelina	SB Member (ABC Representative)
ABSENT:	Hon. Mary Jean G. de los Santos	SB Member (SK Representative)

ORDINANCE NO. 2000-85

AN ORDINANCE PRESCRIBING THE GUIDELINES
ON MONUMENTS HONORING NATIONAL HEROES,
ILLUSTRIOUS FILIPINOS AND OTHER PROMINENT
PERSONAGES IN PUBLIC PLACES.

ON MOTION of the Committee on Tourism Culture and History, namely: Hon. Jose Neil P. Olivares, Hon. Francisca C. Espeleta and Hon. Jose F. Tinapon III and duly seconded by Hon. Edgar N. Javelina

BE IT ORDAINED by the Sangguniang Bayan of Oton, Iloilo, an Ordinance to wit:

SECTION 1. INTRODUCTION.

Monuments of National Heroes, illustrious Filipinos and other prominent personages deserve the highest respect and reverence from the public and such necessitates the passage of this Ordinance which prescribes the guidelines in the placing / installation and maintenance of the above-mentioned monuments.

SECTION 2. DEFINITION OF TERMS.

For purposes of this Ordinance, the following terms are defined as:

1. *National Heroes* - are men and women of exceptional qualities who win the admiration of the entire nation because of their noble deeds, especially deeds of courage, and are declared as national heroes by the concerned government agency(ies).
2. *Illustrious Filipinos* - are persons, although not national heroes, who are conferred the highest public esteem, and are declared as illustrious by the concerned government agency(ies).
3. *Prominent Personages* - are persons of national or local eminence or importance. This includes statesmen, eminent leaders of the Municipality, philanthropist and the like.
4. *Monuments* - are busts, full-bodied statues, figures, pedestals and pylons, arches and the like, erected in memory and in honor of a person or event.
5. *Public places* - are public plazas, squares, courts, open spaces, school grounds, parade grounds, barangay multi-purpose grounds, and the like purposely devoted for public use or purpose.
6. *Monument Service* - an act of cleaning, painting or watering of plants thereat on the monument and its radius by any person found committing any of the acts subject of penalties under Section IV hereof.

SECTION 3. GUIDELINES.

1. DOMINANCE.

The size and configuration of monuments shall not exceed that of the National Hero (Dr. Jose Rizal's) referring to the Rizal Monument in Luneta. If two or more monuments are present at the site including the new one, the more or most important monument shall be given more or the most dominance at the site. The height is likewise controlled by the same ruling.

2. SITE

The placing of monuments shall be properly oriented to the existing set-up of the site. Usually, they are oriented fronting a prominent building or facing a flagpole at the center of an interior courtyard, surrounded by enclosing walls of a building, at the center of a partially opened space, or on an open park or plaza. However, if the site is limited and does not permit the aforementioned conditions, a monument figure may be located side by side (not very near or next to) with the existing flagpole on the same axis parallel to the significant building's façade line, the monument figure, and the flagpole fronting said building. Monuments are generally co-axial with the significant structures around. If there are to be two monuments at the same time on the site, these may be side by side with the flagpole, with the Philippine Flag at the center.

3. DESIGN AND MATERIALS

The design fundamentally shall be based on the over-all character of the site and its peripherals (urban or environmental character). It should be contextual with the site and its vicinity. The proposed design of the monument or site development should adopt to the existing, original, or significant structure. It must not be the reverse process. With regard to the other aspects, the commissioned artist or architect is given the leeway in his own interpretations of the design. Pedestals, plant boxes, platforms, and other low portions of the design shall be carefully studied so as to avoid areas attractive to street dwellers and vandals. The choice of materials shall be to the sound discretion of the artist or architect. However, color, texture, materials matchings and combinations shall be well taken into consideration for a refined overall appearance. Full-bodied monuments are preferably placed on a simple pedestal having the same height or a proportion of 1 : 1 figure to pedestal ratio.

4. STRUCTURE.

The structure of the monument, which may include the platform, the pedestal, the figure, the pylon or the arch, must be rigidly constructed in accordance with the existing National Building Code requirements, and to the accepted engineering practices. Structures located outdoors, must be built to withstand strong winds and earthquakes. Emphasis shall be given to the construction method on mounting of the monument figure to the pedestal.

5. LANDSCAPING AND AMENITIES.

Site development, landscaping and amenities shall depend on the existing site requirements. Local and national government restrictions regarding site development shall be complied with. To give prominence to the monument, the immediate area shall be simple and preferably unobstructed. Unightly installations, including stalls, tents, debris, garbage or shanties existing prior to the site development, shall be cleared from the site.

6. CONCEPTS OF OPEN SPACE AND HISTORICAL PRECEDENTS.

The concept of an open space is that it must remain open, simple neat and should be considered a breathing space and a center for public congregation.

An open space shall be treated more as a natural environment and a space which relates the surrounding structures. It is a whole composition that is homogenous and functional.

Historical precedents must always be respected. This means that existing elements, designs and other features that have gained significance and are considered distinct elements which the town, site, or center is identified with, shall be preserved and protected. Additions or renewals shall only be done to enhance the existing set-up, but not to compete or radically contrast with it, resulting in the discriminate alteration of the meaning and intention of the site.

7. PROPER USE.

All monuments as stated herein shall be treated with utmost respect and reverence, more particularly, full-bodied statues and busts of the country's heroes, illustrious Filipinos and eminent leaders of the Municipality. Desecration in any form is therefore prohibited. They shall be given utmost protection from vandalism, improper use, such as places for herding animals, dumping areas for garbage, gambling dens, venues for illicit activities, and other forms of desecration.

8. MAINTENANCE.

All monuments shall be ensured with proper and continuous maintenance.

The General Services Office, this Municipality, is mandated under this Ordinance to upkeep and maintain the cleanliness and proper use, as stated in paragraph 7 above, the following monuments: Dr. Jose P. Rizal and Jose P. Laurel monuments at the plaza and the Andres Bonifacio Monument along Bonifacio St. or other monuments that may hereinafter be installed by the Local Government. Said Office (GSO), together with an assigned police officer of the Oton PNP shall also manage persons rendering monument services as provided in Section IV hereof. Funds, as far as possible, be appropriated by this Sanggunian for their repair or beautification.

All other monuments located within school premises shall be maintained by their respective schools.

The World War II Veterans Monument in the plaza shall likewise be maintained by its Sponsor – the Veterans Federation of the Philippines, Oton Post or its Sons and Daughters Associations, Incorporated.

9. RELOCATION.

A. Existing monuments **cannot be relocated** without any justifiable reasons. Instances in which monuments cannot be relocated include the following:

- a. If the event which the monument immortalizes occurred in the particular area where the monument now stands,
- b. If relocating the monument will mean the destruction of the monument,
- c. If there was no prior consultation or due process,
- d. If the monument is to be replaced with that of a lesser stature or importance,
- e. If the site to relocate the monument is still uncertain or is not of a better location,
- f. If the monument is left idle or decommissioned,
- g. If the new development plans conflict with that of the existing environment of the monument. The existing monument should be made the point of reference for any development plans, not vice versa.

B. Monuments **can be relocated** if the reasons for its relocation will not conflict with the above reasons. Other instances include the following:

- a. If the new development plan is an accepted improvement over the old plan and does not conflict the old plan. In some instances, a monument is to be added within the area; the new monument shall be placed side by side with the existing monument.
- b. If the positioning of the old monument is to be corrected, e.g., the monument is repositioned to face the flagpole.
- c. If the monument will be replaced with a better monument, e.g., a cement monument being replaced with a bronze monument. In most cases even the old monument is transferred to another appropriate site, but not destroyed.

10. ILLUSTRATIONS.

The following illustrations form as part of these Guidelines for the purpose of illustrating, in figures, the provisions earlier provided specifically on paragraph 2 hereof.

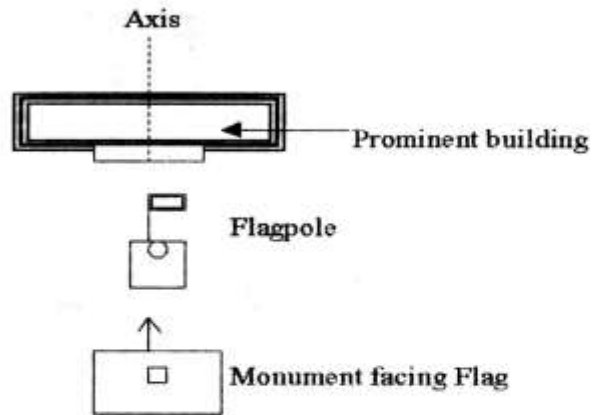

Figure 1. Monument facing Flagpole fronting a Prominent building

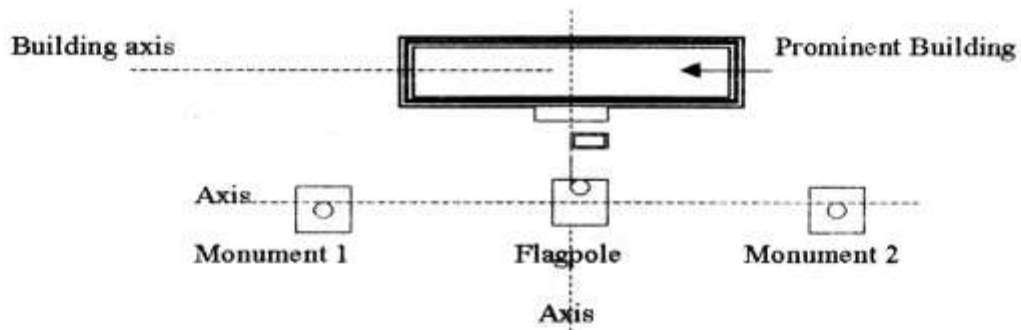
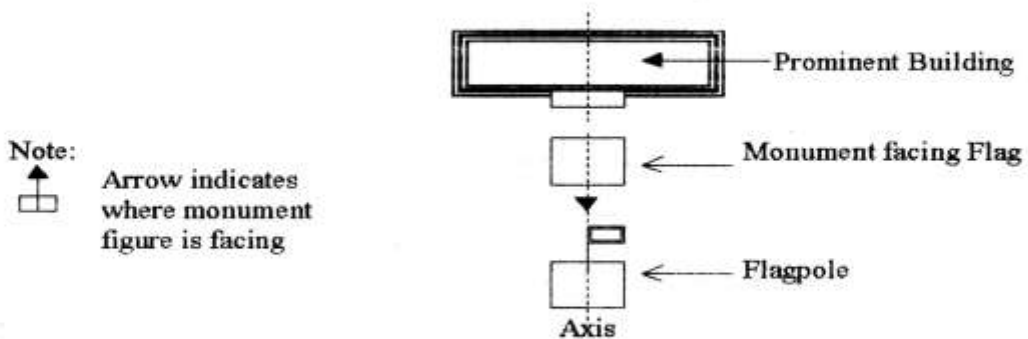

Figure 2: Two monuments side by side with the flagpole on Axis parallel to Prominent Building's Axis.



Note:
 Arrow indicates where monument figure is facing

Figure 3: Monument facing Flagpole

Handwritten notes:
 A
 J
 J
 J

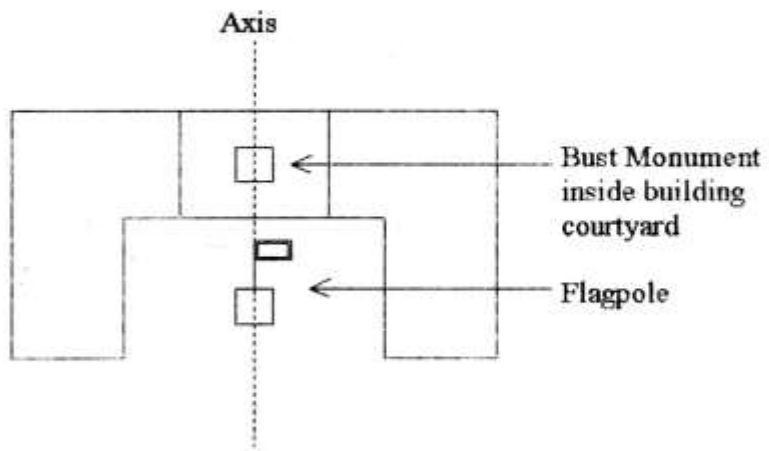
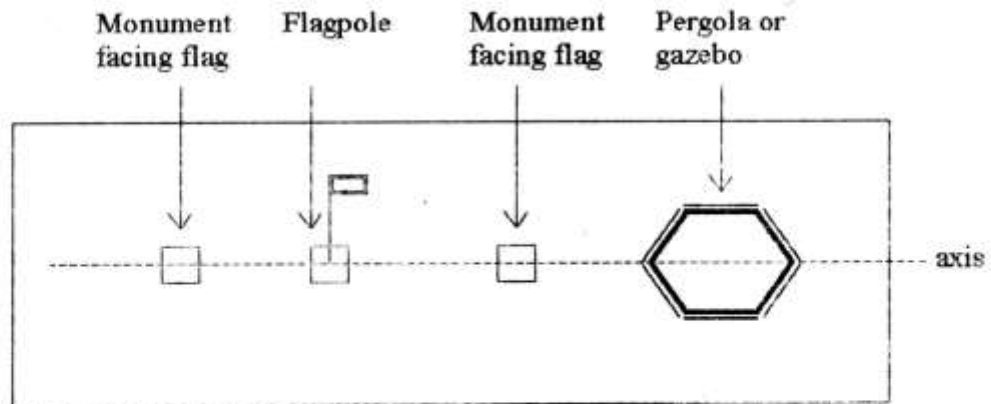

Figure 4: Monument at the center of an Interior Courtyard or at center of Partially opened space.

Handwritten signature



Handwritten signature

Handwritten signature

Figure 5: Monuments on Open Plaza or Park

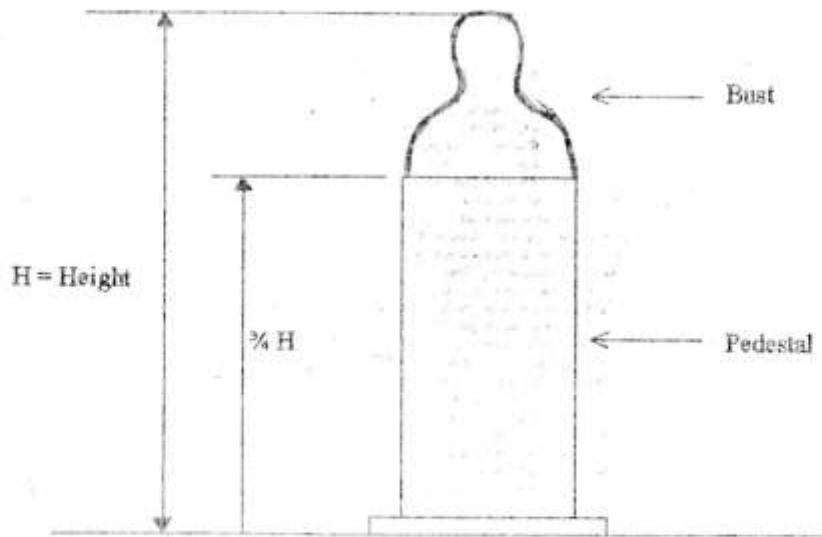

Figure 6: Basic proportion of Bust-Pedestal

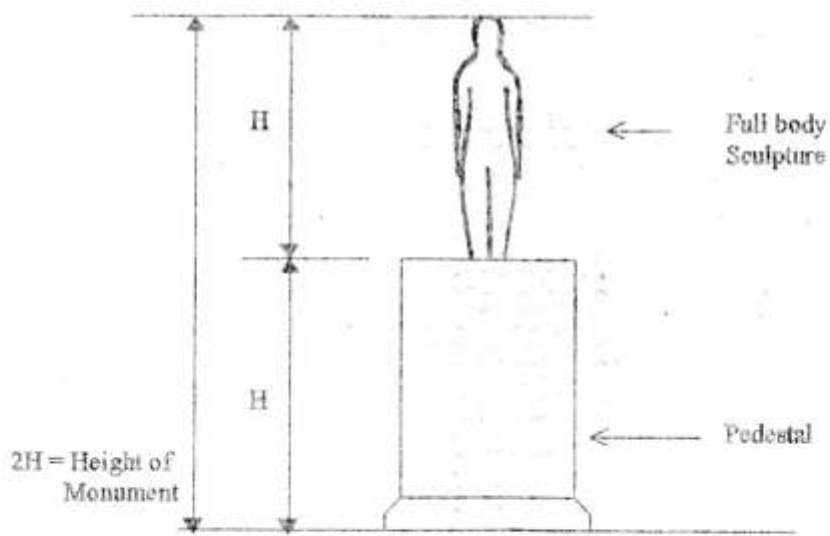

Figure 7: Basic Proportion of Full-Body Sculpture and Pedestal

Five

Handwritten scribbles and marks on the left margin.

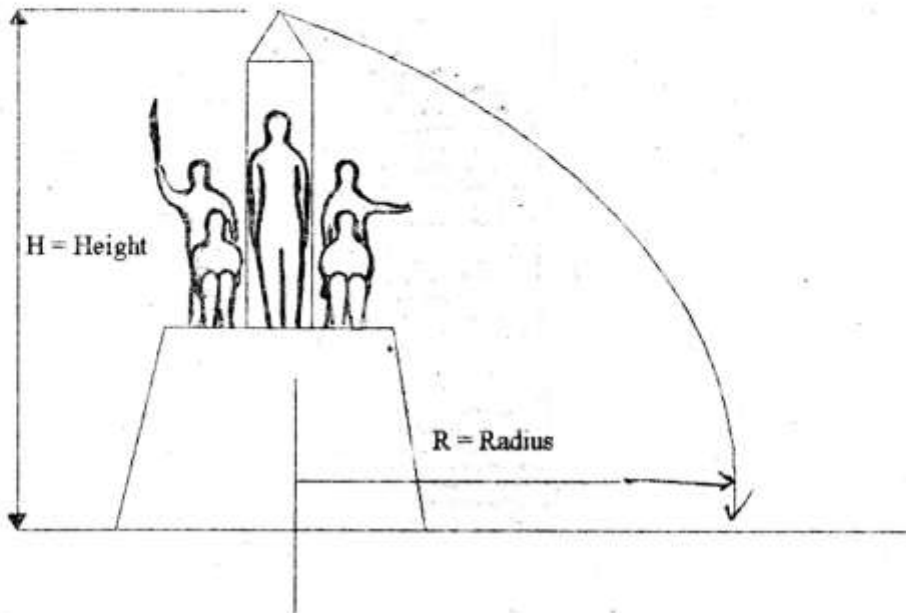

Figure 8: Basic proportion Monument and Radius of immediate periphery

Handwritten notes:
X ju
H
R

SECTION 4. PENALTY CLAUSE.

1. Any public officer violating any of the Guidelines provided in Section 3 hereof shall be administratively liable.
2. Any person who within the 5-meter radius of a monument, commits acts of deformation, vandalism, herding of animals, dumping of garbage, littering, gambling and other illicit activities shall be meted the following penalties:
 - a. *Acts resulting to deformation of monument* – aside from restitution, pay a fine of two hundred pesos (P200.00) or render eight (8) hours monument service, if act is willful, aside from restitution, pay a fine of four hundred pesos (P400.00) or render sixteen (16) hours monument service or both fine and monument service at the discretion of the court;
 - b. *Vandalism* – aside from restitution, pay a fine of two hundred pesos (P200.00) or render monument service of eight (8) hours or both fine and monument service at the discretion of the court;
 - c. *Herding of animals* – aside from restitution or payment of corresponding damage, pay a fine of four hundred pesos (P400.00) or render monument service of eight (8) hours or both fine and monument service at the discretion of the court;
 - d. *Dumping of garbage* – aside from restitution or payment of corresponding damage, pay a fine of four hundred pesos (P400.00) or render monument service of sixteen (16) hours or both fine and monument service at the discretion of the court.
 - e. *Littering* – aside from restitution, pay a fine of two hundred pesos (P200.00) or render eight (8) hours monument service; or both fine and monument service at the discretion of the court.
 - f. *Gambling* – pay a fine of four hundred pesos (P400.00) or render sixteen (16) hours monument service or both fine and monument service at the discretion of the court.
 - g. *Other illicit activities which include making the monument radius as venue for illegal drug trade, white slavery, etc.* – pay a fine of four hundred pesos (P400.00) or render sixteen (16) hours monument service or both fine and monument service at the discretion of the court.

SECTION 5. SEPARABILITY CLAUSE.

If any of the provisions hereof be declared invalid or be amended, the other provisions not so declared or not so amended shall remain in full force and effect.

SECTION 6. EFFECTIVITY CLAUSE.

This Ordinance shall take effect after ten (10) days of posting in at least two (2) conspicuous places in the Municipality.

UNANIMOUSLY APPROVED.

I HEREBY CERTIFY to the correctness of the foregoing Ordinance.

Attested:

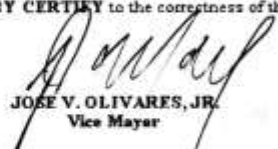

JOSE V. OLIVARES, JR.
Vice Mayor

Concurred:

NICOLAS C. DAMASCO
Secretary to the Sanggunian

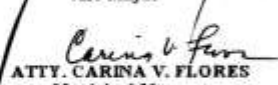
Approved:

ATTY. CARINA V. FLORES
Municipal Mayor

VICENTE E. FLORES, JR.
Floor Leader

Date Approved:

MAR 06 2001

Date Posted:

_____/_____/_____

Mo - 3-27-201

MEO - 3/27/201

MPDC - 3/27/01

DECS 3/27/2001 - cc (16)

RENHE - 3/27/01

S. P. H. S. 3/27/01

4/10/2001 Batuan - Casinglian NHS

ENHS - 4/18/01